

TRAILER MOUNTED BOOM LIFT

MHP13AT

DIMENSIONS MHP13AT

Max.height	12.9m
Max. platform height (A)	10.9m
Horizontal outreach	6.4m
Platform size	1.15m x 0.7m
Overall width (outriggers extended)	4.2m
Overall width (outriggers retracted) (B)	1.6m
Overall length (C)	4.9m
Transport length (D)	2.0m

PERFORMANCE

Platform capacity	215kg
Max. wind speed	12.5m/s
Levelling	auto
Turntable rotation	540° non-continuous
Tyres	185 R14 102/100P
Brakes	Hydraulic over-run non free reversing
Insulation rating	Nil
Trailer tongue weight	80kg

POWER

Power source	Honda petrol
--------------	--------------

WEIGHT

Gross weight	1,460kg
--------------	---------

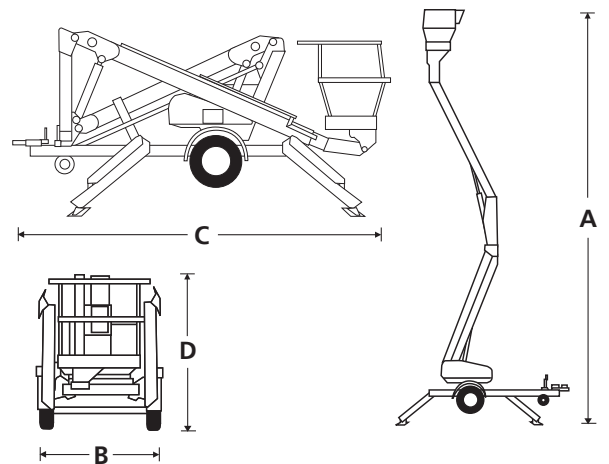

STANDARD FEATURES

- Heavy duty tow coupling
- Hydraulic stabilisers
- Two man steel platform
- Two person capacity
- Heavy duty jockey wheel
- Hydraulic disc brakes
- Reliable petrol engine
- Outrigger boom safety interlocks
- Platform foot switch
- Spare wheel
- LED taillights
- Lifting lugs
- Automatic self-levelling stabilisers
- Rotating basket mount
- Basket overload

WORKING ENVELOPE

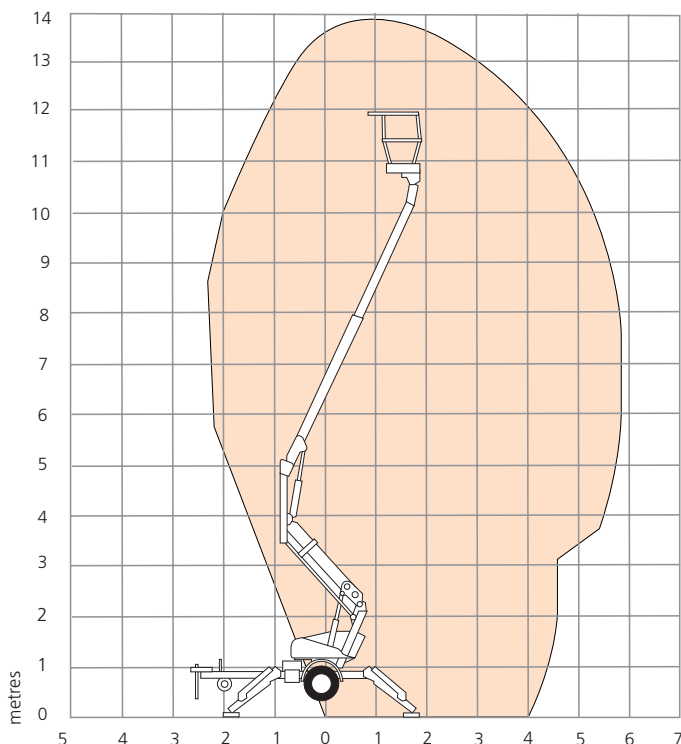

1300 966 088

betterrentals.com.au